

JKB / JKT

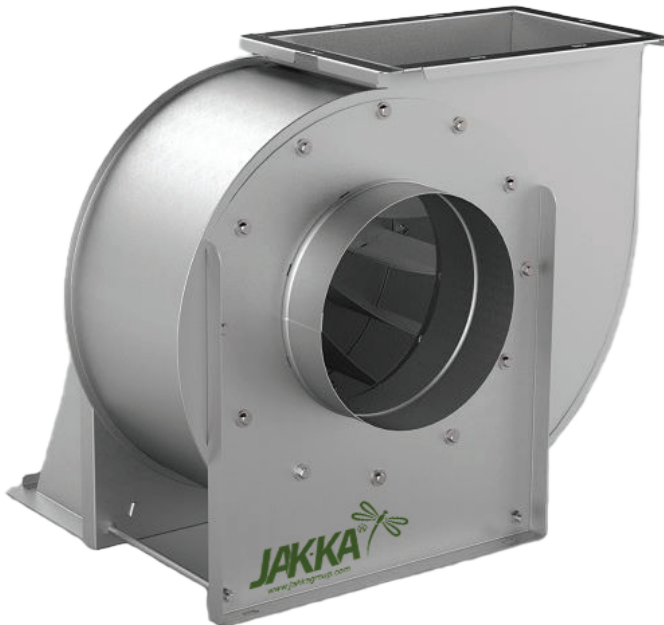

Centrifugalni ventilator sa dovodom vazduha sa jedne strane. Napravljen od pocinkovanog lima, sa napred zakrivljenim radnim kolom. Koriste se za dovod ili odvod vazduha u kuhinjama, restoranima, hotelima, farbarama itd.

Centrifugal fan for with air supply from one side. With strong construction made of galvanized steel sheet. High-performance galvanized impeller with forward curved blades. The fans are suitable for supplying or exhausting air, they are used in professional kitchens, restaurants, hotels, workshops, car painting cabinets, etc.

Materijal / Material

Pocinkovan čelik
Galvanized steel

Pakovanje / Package

1 kom
1 pcs

Klasa hermatičnosti motora /
Motor ingress protection class

IP56

Klasa izolacije motora /
Motor isolation class

F

Napajanje / Power supply

230V / 50Hz - 400V / 50Hz





MONOFAZNI

Model	Napajanje [V/50Hz]	Snaga		Jačina struje (A)	Protok [m ³ /h]	Broj obrtaja [rpm]	Prirubnica Ø [mm]
		[kW]	[HP]				
Četvoropolni							
JKB/4-200/050	220	0.37	0.5	2,70	2500	1400	200
JKB/4-250/100		0.75	1	4,90	5000		250
JKB/4-250/150		1.1	1.5	10,00	6000		250
JKB/4-300/200		1.5	2	10,00	8000		300

TROFAZNI

Model	Napajanje [V/50Hz]	Snaga		Jačina struje (A)	Protok [m ³ /h]	Broj obrtaja [rpm]	Prirubnica Ø [mm]
		[kW]	[HP]				
Četvoropolni							
JKT/4-300/200	230/400	1.5	2	6/3,5	8000	1400	300
JKT/4-350/300		2.2	3	8,4/4,89	9000		350
JKT/4-350/400		4	5.5	12,4/7,2	11.000		350

TEHNIČKA SPECIFIKACIJA TECHNICAL SPECIFICATION

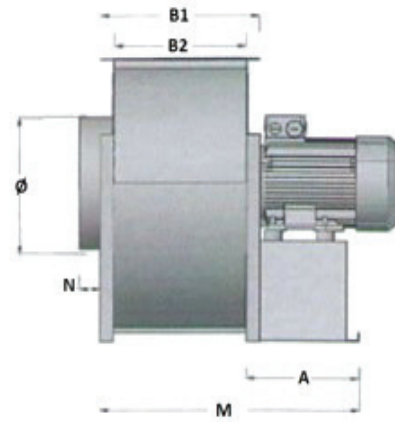
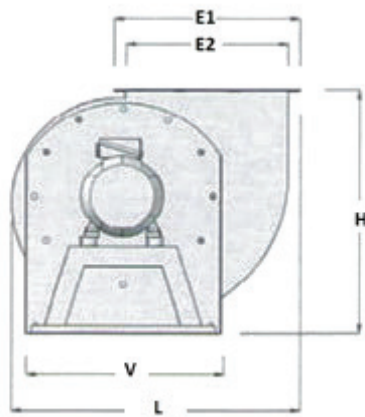

Model	Dimenzije (mm)								
	H	L	M	V	E1*B1	E2*B2	fi	N	A
JKB/4-200/050	455,5	540	430	375	298*260	235*200	200	55	200
JKB/4-250/100	537	625	460	420	395*270	335*210	250	55	220
JKB/4-250/150	537	625	460	420	395*270	335*210	250	55	220
JKB/4-300/200	630	740	585	510	420*350	360*290	300	55	270
JKT/4-300/200	630	740	585	510	420*350	360*290	300	55	270
JKT/4-350/300	715	790	690	513	485*390	423*330	350	80	280
JKT/4-350/400	715	790	690	513	485*390	423*330	350	80	280

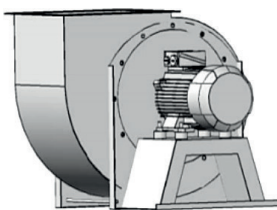

RD0

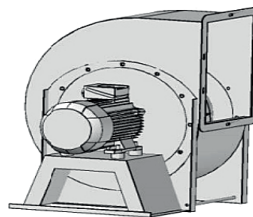

RD90

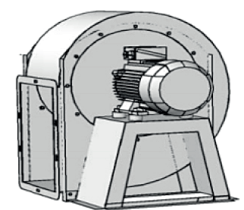

RD270

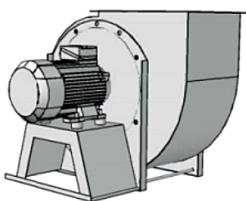

LG0

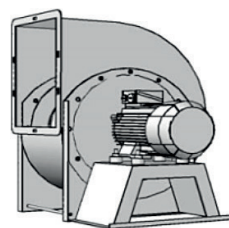

LG90

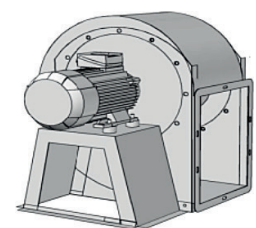

LG270

