

FKKB/FKKT

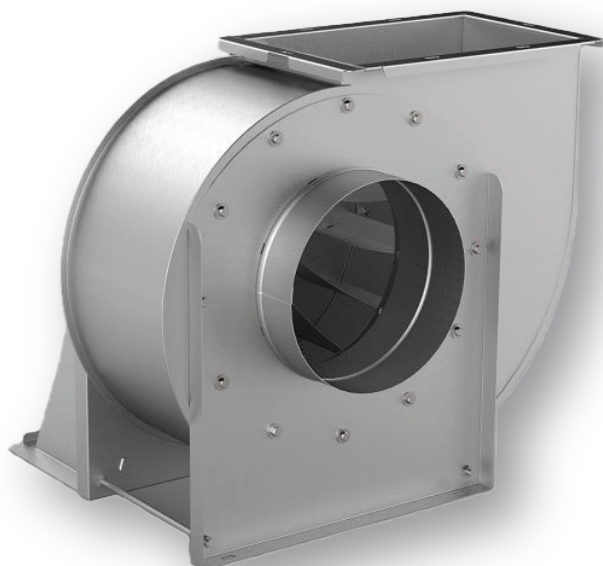

Centrifugalni ventilator sa jednim usisom. Proizvedeno za komercijalne i industrijske kuhinje koje u svom sistemu ventilacije poseduju filtere i dampere.

Single inlet centrifugal fan. Designed for commercial and industrial kitchens where high system resistances are present as system with filters, dampers...

Materijal / Material

Pocinkovan čelik
Galvanized steel

Pakovanje / Package

1 kom
1 pc

Klasa zaštite motora / Motor ingress protection class

IP55

Klasa izolacije motora / Motor insulation class

F

Regulisanje brzine / Speed control

Regulator brzine REM, Frekventni regulator
Rheostat REM, Inverters

Napajanje / Power supply

230V / 50Hz - 400V / 50Hz

Opseg temperature / Temperature range

-40 °C / +70 °C



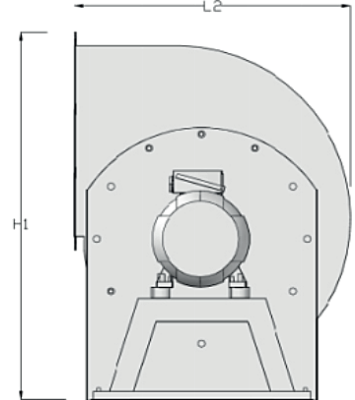
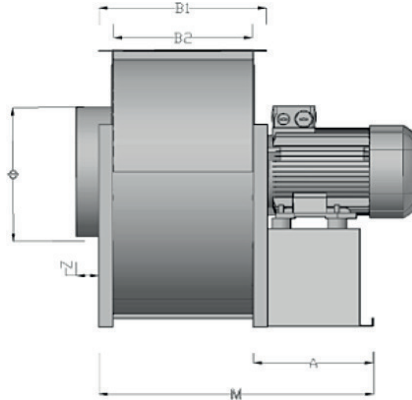
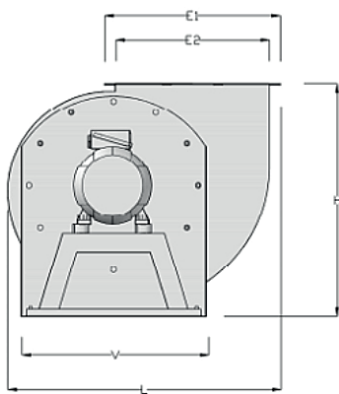

TIP TYPE	H	L	H1	L1	M	V	E1*B1	E2*B2	Ø	N	A
FKK 200	455	510	565	450	430	380	290*255	240*200	195	60	200
FKK 250	540	625	680	515	470	424	395*270	340*215	245	60	220
FKK 300	630	740	785	615	592	518	434*350	370*290	295	60	270
FKK 350	710	780	890	670	695	518	490*394	425*330	345	70	320
FKK 400	720	790	910	690	665	545	565*410	495*335	395	65	290
FKK 450	845	950	1055	800	890	640	620*510	470*435	445	80	417

Orijentacija ventilatora Fan assembly

* RD0 i LG0 su standardne orijentacije ventilatora
RD0 and LG0 are standard fan assembly

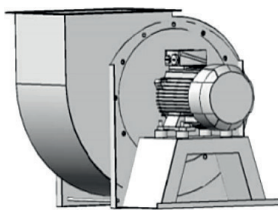

RD0

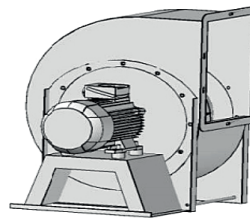

RD90

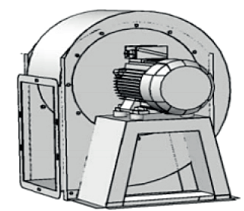

RD270

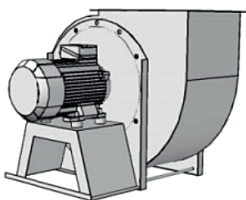

LG0

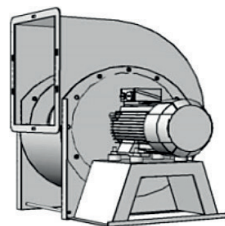

LG90

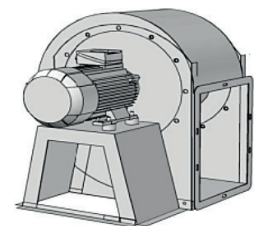

LG270

TEHNIČKA SPECIFIKACIJA TECHNICAL SPECIFICATION

MONOFAZNI								
Model	Napajanje	Snaga		Jačina struje (A)	Protok [m ³ /h]	Broj obrtaja [rpm]	Prirubnica Ø [mm]	Regulacija
		[kW]	[HP]					
Četvoropolni								
FKKB/4-200/050	230V/50HZ	0,37	0,5	2,79	2.400	1400	200	REM 5
FKKB/4-250/100		0,75	1	4,69	4.000	1410	250	REM 10
FKKB/4-250/150		1,1	1,5	6,87	4.400	1410	250	REM 10
FKKB/4-300/200		1,5	2	9,12	7.150	1420	300	ON-OFF
Šestopolni								
FKKB/6-250/050	230V/50HZ	0,37	0,5		3.000		250	ON-OFF
FKKB/6-300/100		0,75	1		5.200	950	300	ON-OFF
FKKB/6-300/150		1,1	1,5		5.400		300	ON-OFF
FKKB/6-350/200		1,5	2		3.250		350	ON-OFF
TROFAZNI								
Model	Napajanje	Snaga		Jačina struje (A)	Protok [m ³ /h]	Broj obrtaja [rpm]	Prirubnica Ø [mm]	Regulacija
		[kW]	[HP]					
230V/400V								
Četvoropolni								
FKKT/4-200/050	230V/400V/50HZ	0,37	0,5	1,82 / 1,05	2.400		200	Parker AC10 10G-42-0015-BN
FKKT/4-250/100		0,75	1	3,21 / 1,85	4.000		250	Parker AC10 10G-42-0020-BN
FKKT/4-250/150		1,1	1,5	4,68 / 2,69	4.400		250	Parker AC10 10G-42-0030-BN
FKKT/4-300/200		1,5	2	6,2 / 3,56	7.150	1450	300	Parker AC10 10G-42-0040-BN
FKKT/4-350/300	400V/50HZ	2,2	3	/ 4,79	8.300		350	Parker AC10 10G-42-0065-BN
FKKT/4-350/400		3	4	10,97 / 6,31	8.500		350	Parker AC10 10G-43-0080-BN
FKKT/4-400/550		4	5,5	8,17	9.800		400	Parker AC10 10G-43-0090-BN
FKKT/4-450/750		5,5	7,5	10,78	14.400		450	Parker AC10 10G-43-0120-BN
Šestopolni								
FKKT/6-250/050	230V/400V/50HZ	0,37	0,5	1,97 / 1,13	3.000		250	Parker AC10 10G-42-0015-BN
FKKT/6-300/100		0,75	1	3,67 / 2,11	5.200		300	Parker AC10 10G-42-0020-BN
FKKT/6-300/150		1,1	1,5	5,23 / 3,01	5.400	950	300	Parker AC10 10G-42-0030-BN
FKKT/6-350/200		1,5	2	6,47 / 3,72	6.250		350	Parker AC10 10G-42-0040-BN
FKKT/6-400/300	400V/50HZ	2,2	3	8,89 / 5,11	7.500		400	Parker AC10 10G-42-0065-BN
FKKT/6-450/550		4	5,5	8,92	12.500		450	Parker AC10 10G-43-0090-BN

Svi modeli 220V/50Hz u ovoj seriji imaju termičku zaštitu u motoru.

Modeli 400V/50Hz moraju biti povezani sa termičkom zaštitom od strane električara.

All models 220V/50Hz in this series incorporate thermal protection in the motor wiring.

Models 400V/50Hz must be connected with thermal protector by electrician.





Ventilatori Fans

TEHNIČKA SPECIFIKACIJA TECHNICAL SPECIFICATION

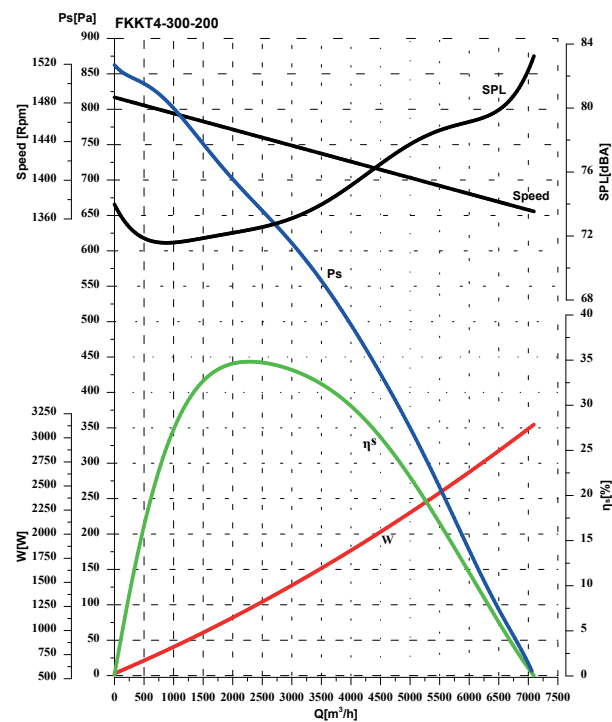
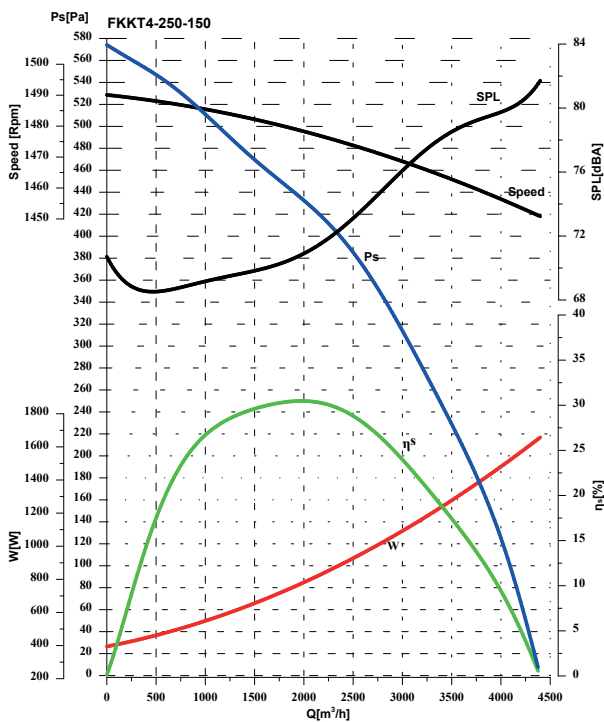
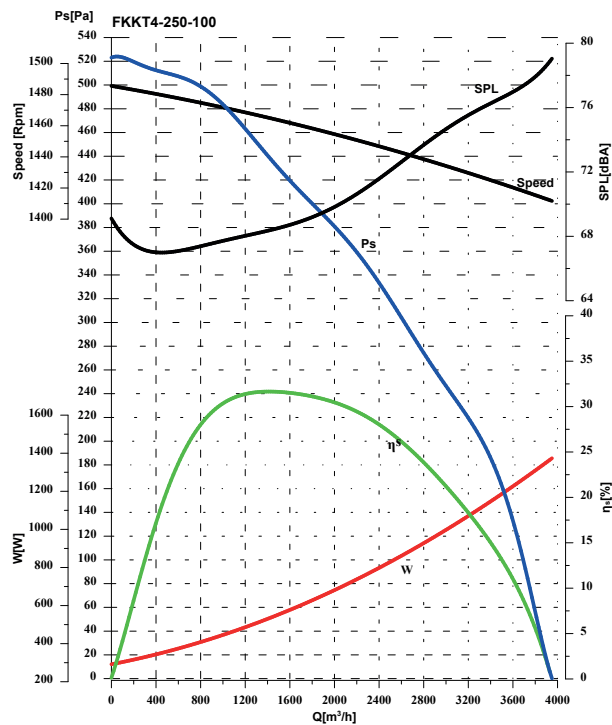
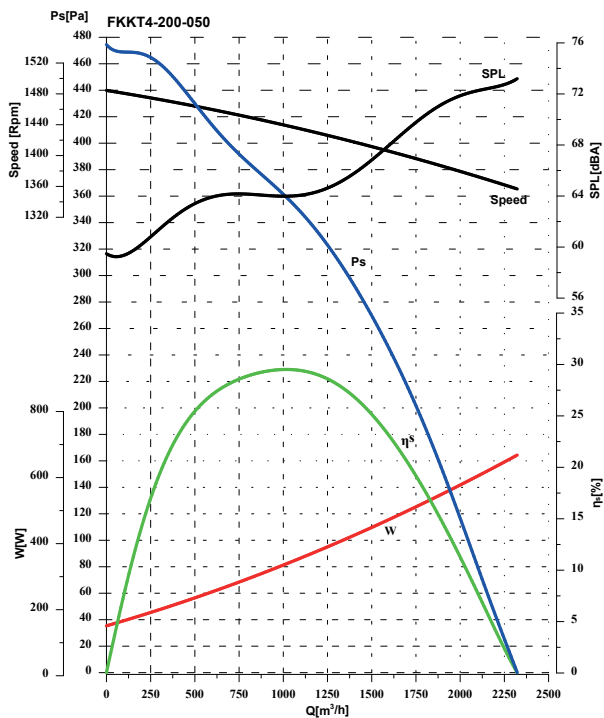

TEHNIČKA SPECIFIKACIJA TECHNICAL SPECIFICATION

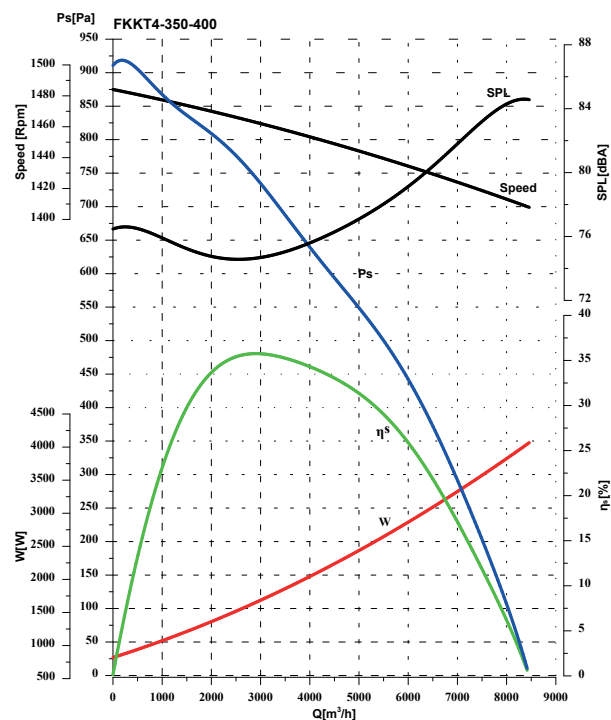
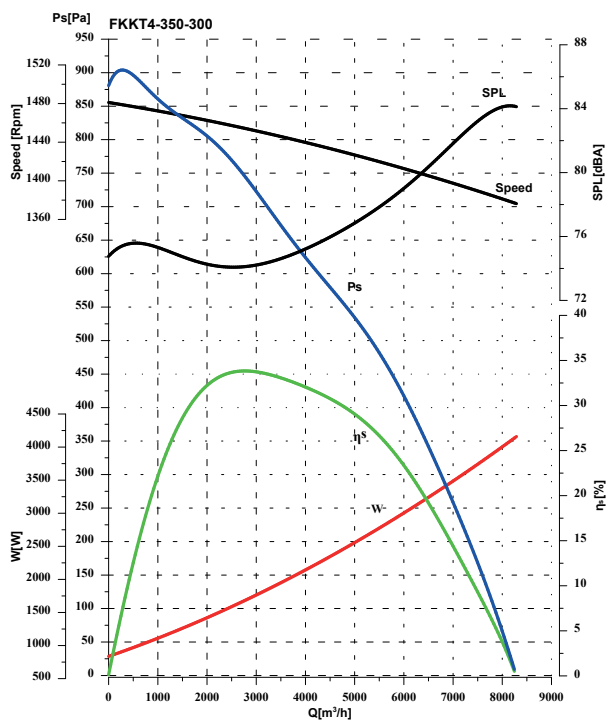
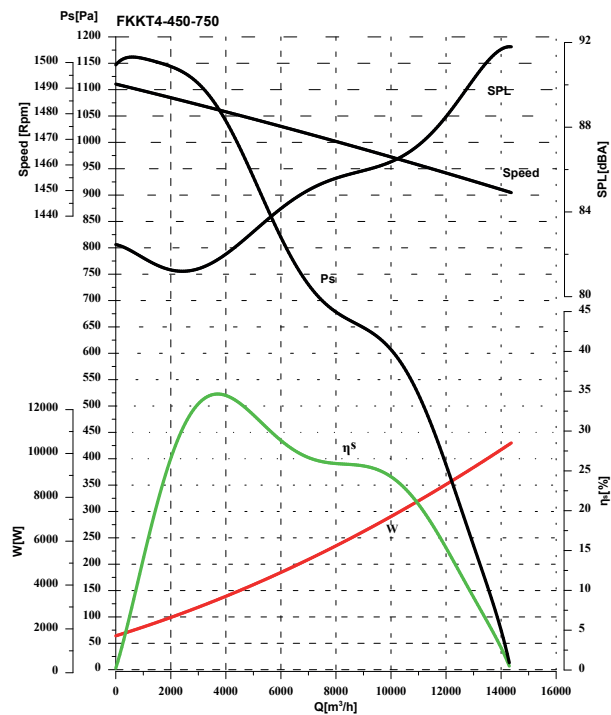
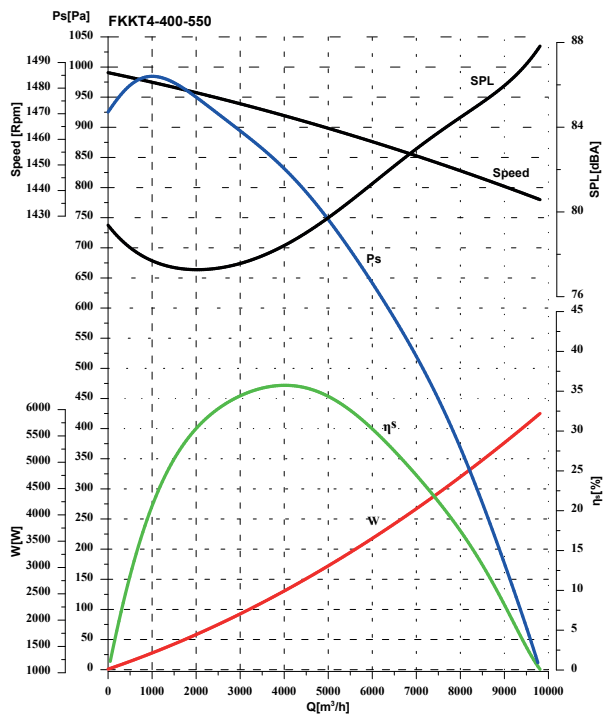

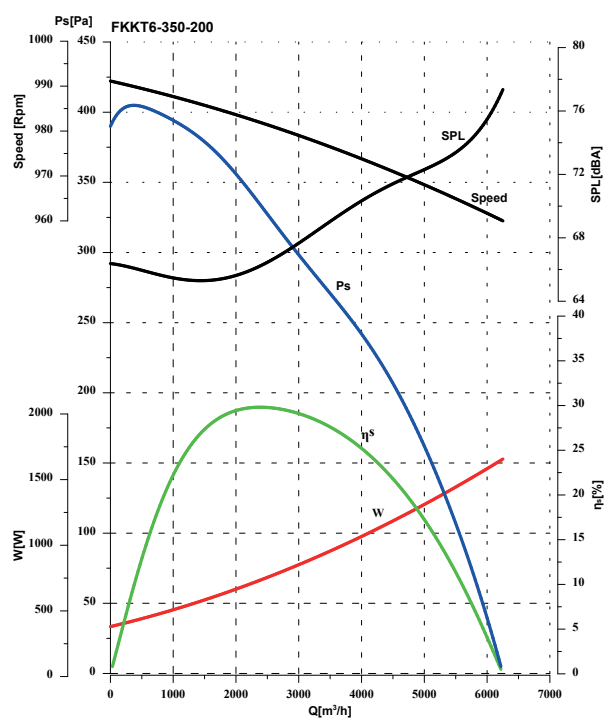
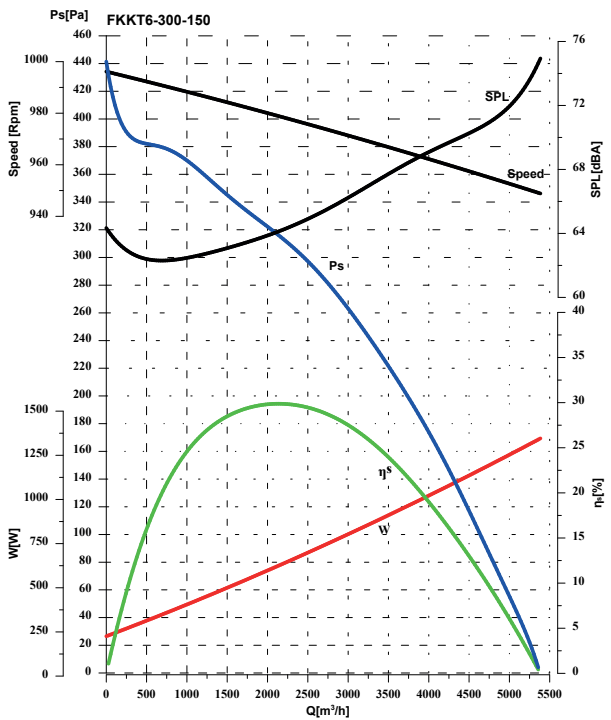
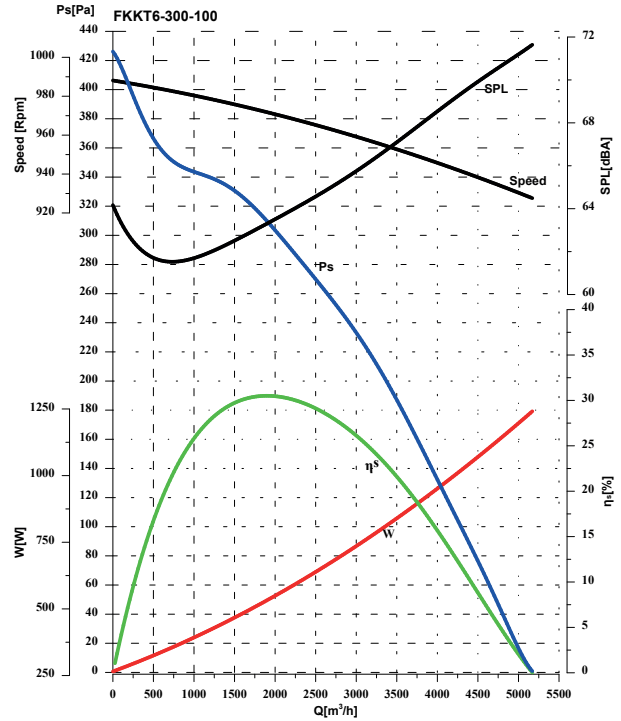
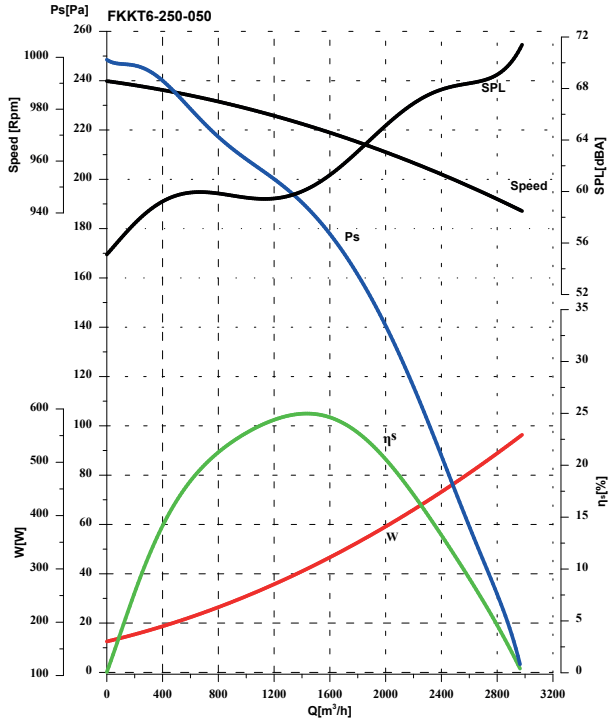

TEHNIČKA SPECIFIKACIJA TECHNICAL SPECIFICATION

